



# Australian Aboriginal Cultures Gallery - Level 1

## Primary Years - A4 Student Guide



Principal Sponsor



This Outreach Education Program for schools is made possible by the partnership between the South Australian Museum and the Department of Education and Children's Services. Outreach Education is a team of seconded teachers who are based in public institutions.

© Department of Education and Children's Services and SA Museum

This work may be reproduced by South Australian teachers for use with their students. For all other uses contact the S.A. Museum Education Service.

Authors: Chris Nobbs and Simon Langsford

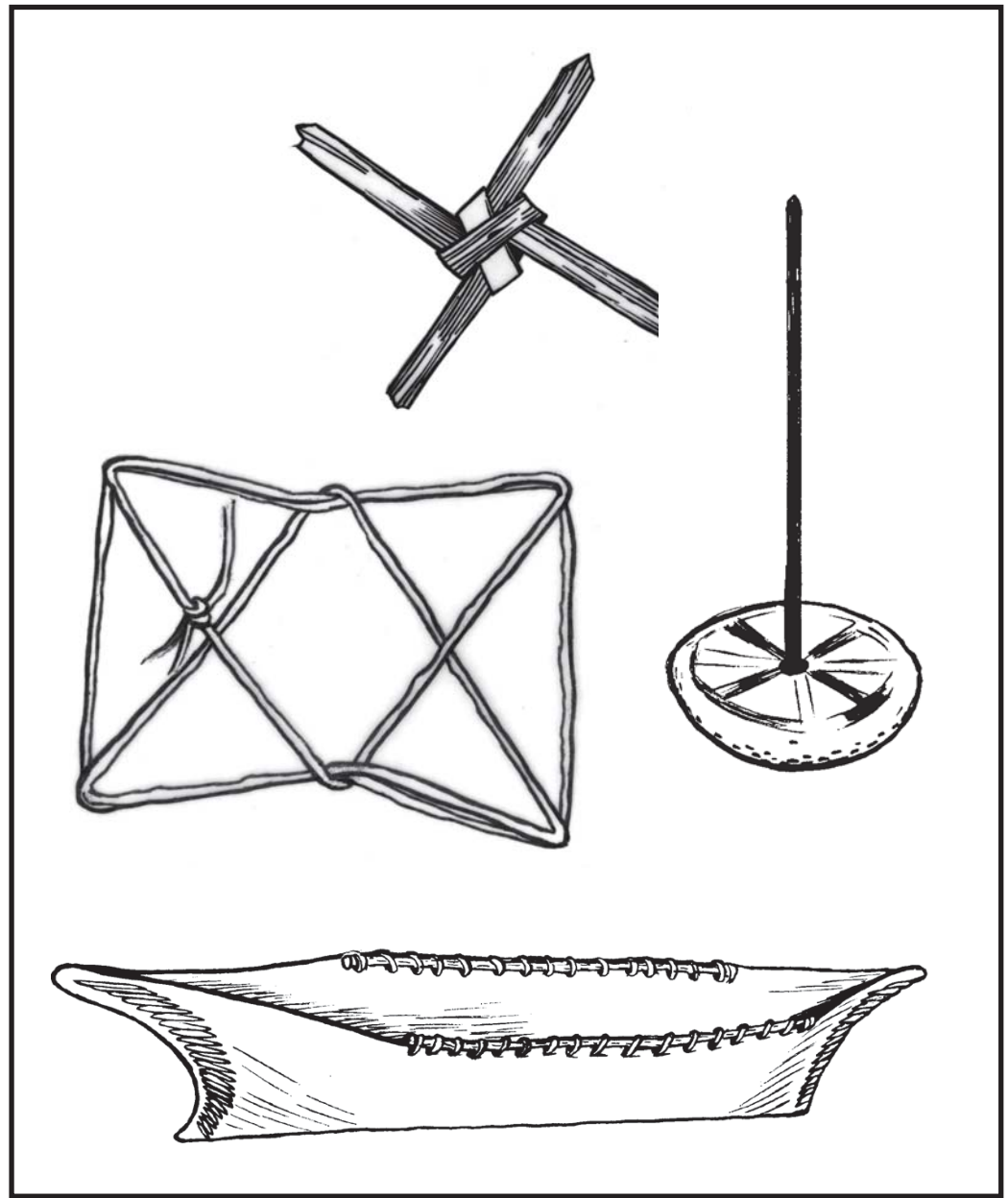

# South Australian Museum Education Program

Phone: (08) 8207 7429 • Fax (08) 8207 7430 • Email: SAM.Education@saugov.sa.gov.au • Web: www.samuseum.sa.gov.au

# Australian Aboriginal Cultures Gallery - Level 1

## Primary Years - Student Guide

### Aboriginal art and the Dreaming (Please do not touch the paintings.)

#### Paintings on bark

Aboriginal artists in northern Australia paint their Dreaming Ancestors on bark. Look at the bark paintings hanging on the eastern wall.

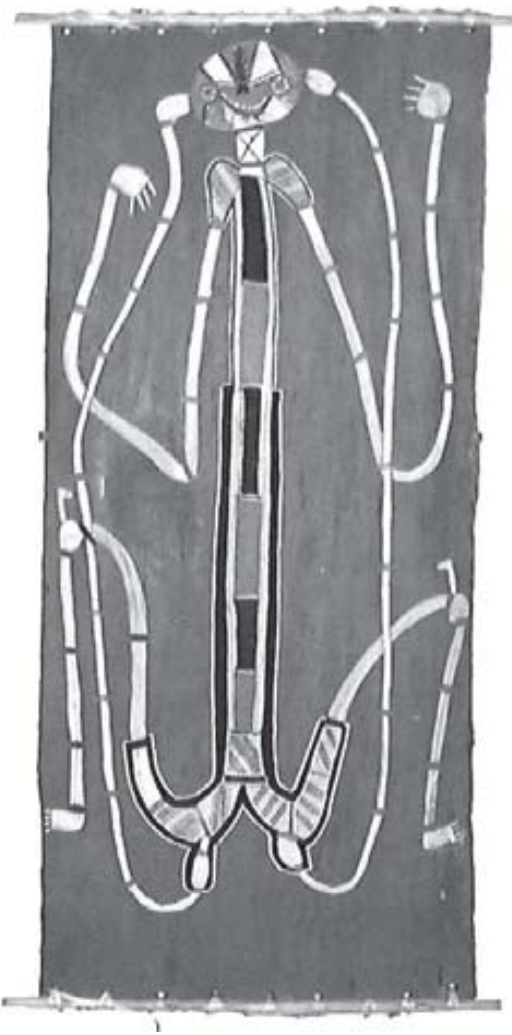

Find this painting or another one done on bark.

Describe what is in the painting.

---

---

---

---

---

---

# Australian Aboriginal Cultures Gallery - Level 1

## Primary Years - Student Guide

### Baskets (Near the southern doorway.)

Aboriginal people have collected the raw materials they need to make things from the environment for thousands of years.

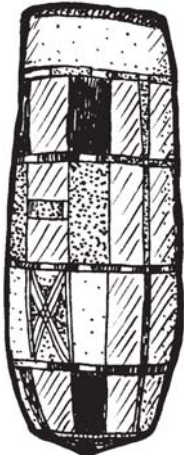

Find some Aboriginal baskets on display that were used to carry things.

Are all the baskets made of the same material?

\_\_\_\_\_ What do you think they are made of?

\_\_\_\_\_

Basket work was sometimes used to make things that were not baskets.

Try drawing something on display that is not a basket, but is made the same way as a basket?



### String

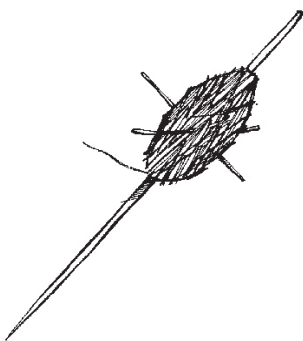

Find the string display nearby.

How many different kinds of string can you find?

\_\_\_\_\_

Describe *two* things Aboriginal people made string from.

\_\_\_\_\_

2. \_\_\_\_\_

String is important. It is used to tie things up.

Find *two* other things in another part of the display that are made using string and other materials. What did you find?

1. \_\_\_\_\_ 2. \_\_\_\_\_

# Australian Aboriginal Cultures Gallery - Level 1

## Primary Years - Student Guide

### Boomerangs

Find the boomerang display.



Can you find the pull-out door too? (*It is on the left of the window.*)

There are many different shaped boomerangs on display.  
Try drawing some of their shapes here.

What do you think some of these different shaped boomerangs were used for?

---

---

### Woodworking

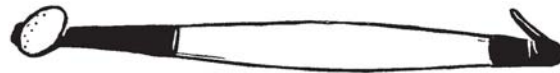

Aboriginal people made many of the things on display out of wood.  
Look around the gallery and find a wooden tool or a weapon.  
Try drawing it here.

Name: \_\_\_\_\_

Used for: \_\_\_\_\_

How I think it was made: \_\_\_\_\_

\_\_\_\_\_

\_\_\_\_\_

Other materials used:

# Australian Aboriginal Cultures Gallery - Level 1

## Primary Years - Student Guide

### Around Australia

Aboriginal people live in different parts of Australia.

Look for the special displays about Aboriginal people from the **Tiwi Islands**, **Western Cape York**, the **Kimberly** region and **Kakadu**.



*Thompson, Arnhem Land*

Choose your favourite display and answer these questions. (*Look for the big white signs to find the displays.*)

What place have you chosen? \_\_\_\_\_

Listen to one of the people speaking on the video screen in this display. Write down one of the things they are talking about.

---

---

Describe two things from this display that were used for:

1. Gathering food or hunting \_\_\_\_\_

---

2. Decoration \_\_\_\_\_

---

Find two things from that were not used for used for getting food or decoration. What are they?

---

---



# Australian Aboriginal Cultures Gallery - Level 1

## Primary Years - Student Guide

### Tools

Find a tool used by Aboriginal people in the past that does the same job as a tool you have at home today. Try drawing it here.

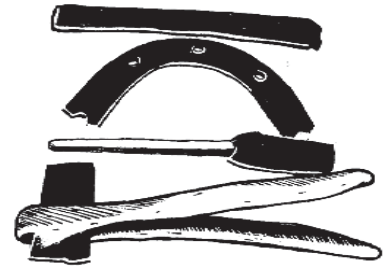

What does the tool do?

---

---

In what way is the Aboriginal tool different to the tool you have at home?

---

Why did Aboriginal people make it differently in the past?

---

Do you think Aboriginal people still make this kind of tool today?

\_\_\_\_\_ Why not? \_\_\_\_\_

People need to solve many problems to stay healthy and happy. Find something that Aboriginal people invented to solve these problems. Write down what you find.

Problem	Invention that solves this problem
I have no food to eat.	
I cannot carry all my things.	
I want people to remember my story.	